



LIGHT & ACOUSTICS



Tony Decavele
CEO & Founder



WHO AND WHAT IS ZUMI



Creating solutions for

OFFICE – RETAIL – HEALTHCARE – HOSPITALITY - RESIDENTIAL



Who and what is

ZUMI was founded in 2016 by Tony Decavele who, with his 30 years of experience in lighting, can count on a lot of project experience and knowledge. ZUMI focuses on the combination of lighting, acoustic solutions and lighting control systems.

ZUMI develops and produces for Hospitality, Retail, Healthcare and residential projects. Today, the range includes some 80 luminaires for recessed and surface-mounted, track-light, profiles, pendants, ... and light management systems. Customisation is also offered for specific integrations.

Since August 2018, ZUMI has been housed in the industrial zone of Gistel at Nieuwpoortsesteenweg 178, where investments will also be made in an experience room, meeting room and technical room. There is also the possibility of further expansion at this location in the future.

Although ZUMI is a young player in the lighting world, 3 AWARD's can already be displayed, such as the DESIGN X50 Kortrijk, Surface Design Award London and MIAW Award Paris. These awards give international recognition and can lead to further growth. They are an incentive to continue to innovate and invest in new creative solutions with the necessary technology to make LIGHT "smart" by the integration of IOT (Internet of Things).



DESIGN AWARDS





**SURFACE
DESIGN
AWARDS
2018 | WINNER**



BELGIUM – LONDON - PARIS





LIGHT & ACOUSTICS

PORTFOLIO



LIGHT & ACOUSTICS

RED LINE in the ZUMI products

Lightcolors from 1800K – 7000K
Tunable white
PI-LED technology
DIM 2 WARM
Different DIM systems
High performed reflectors and lenses
Bluetooth and WIFI solutions
Sensors
High CRI
5 years warranty
Made in Belgium
Acoustics: alpha W 0,9



ON TRACK

Fixtures on track systems



LIGHT & ACOUSTICS

EUTRAC

www.zumi.be/eu-track

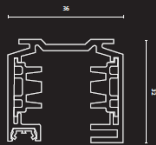

Surface

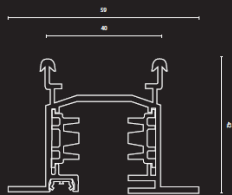

Recessed

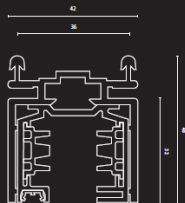

Trimless

STUCCHI 48V MAGNETIC TRACK

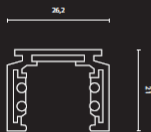

Surface

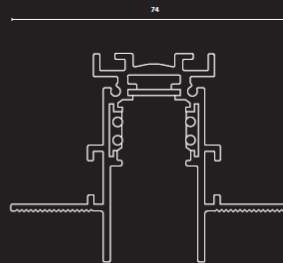
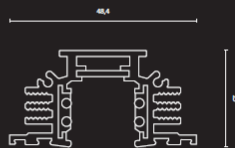

Surface

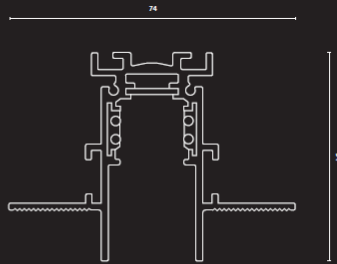

STUCCHI ONETRACK

www.zumi.be/stucchi_one-track

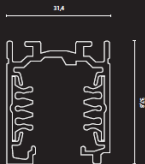

Surface

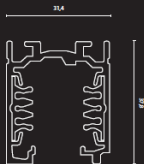

Recessed

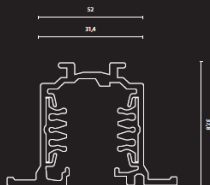

LIGHT & ACOUSTICS

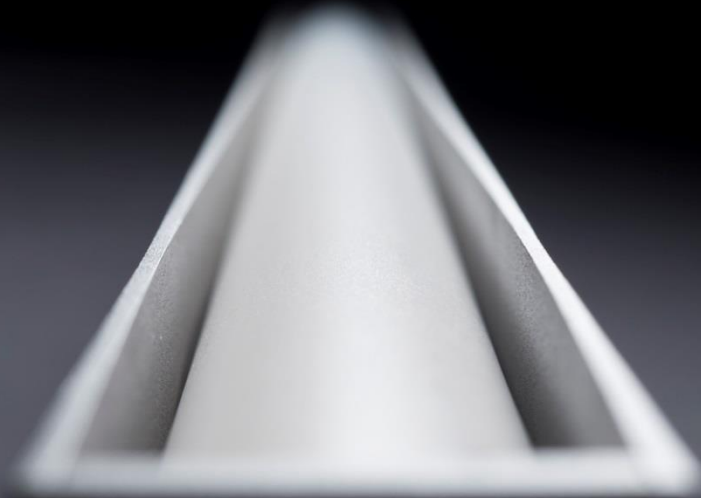

COPTER



LIGHT & ACOUSTICS

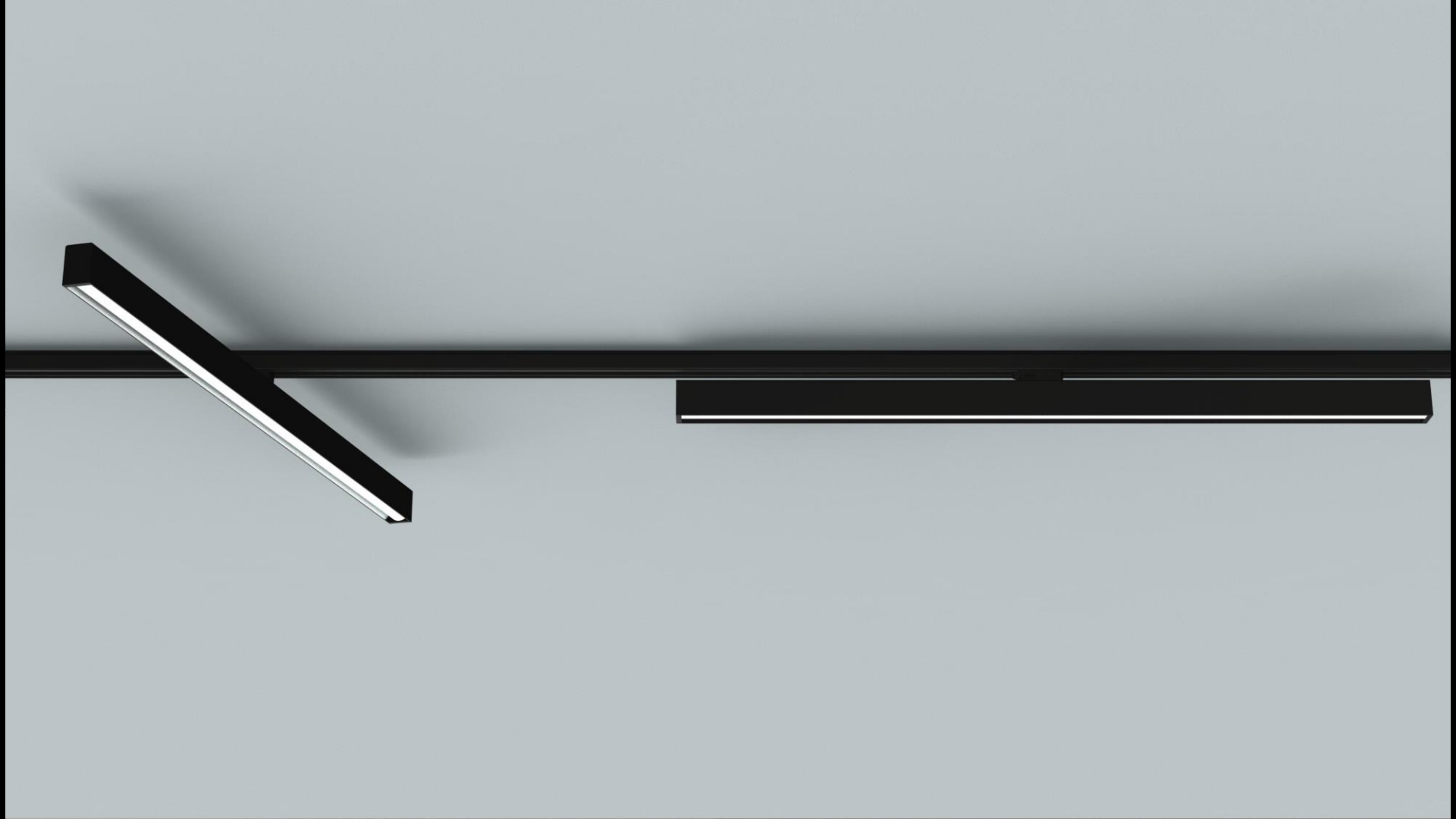



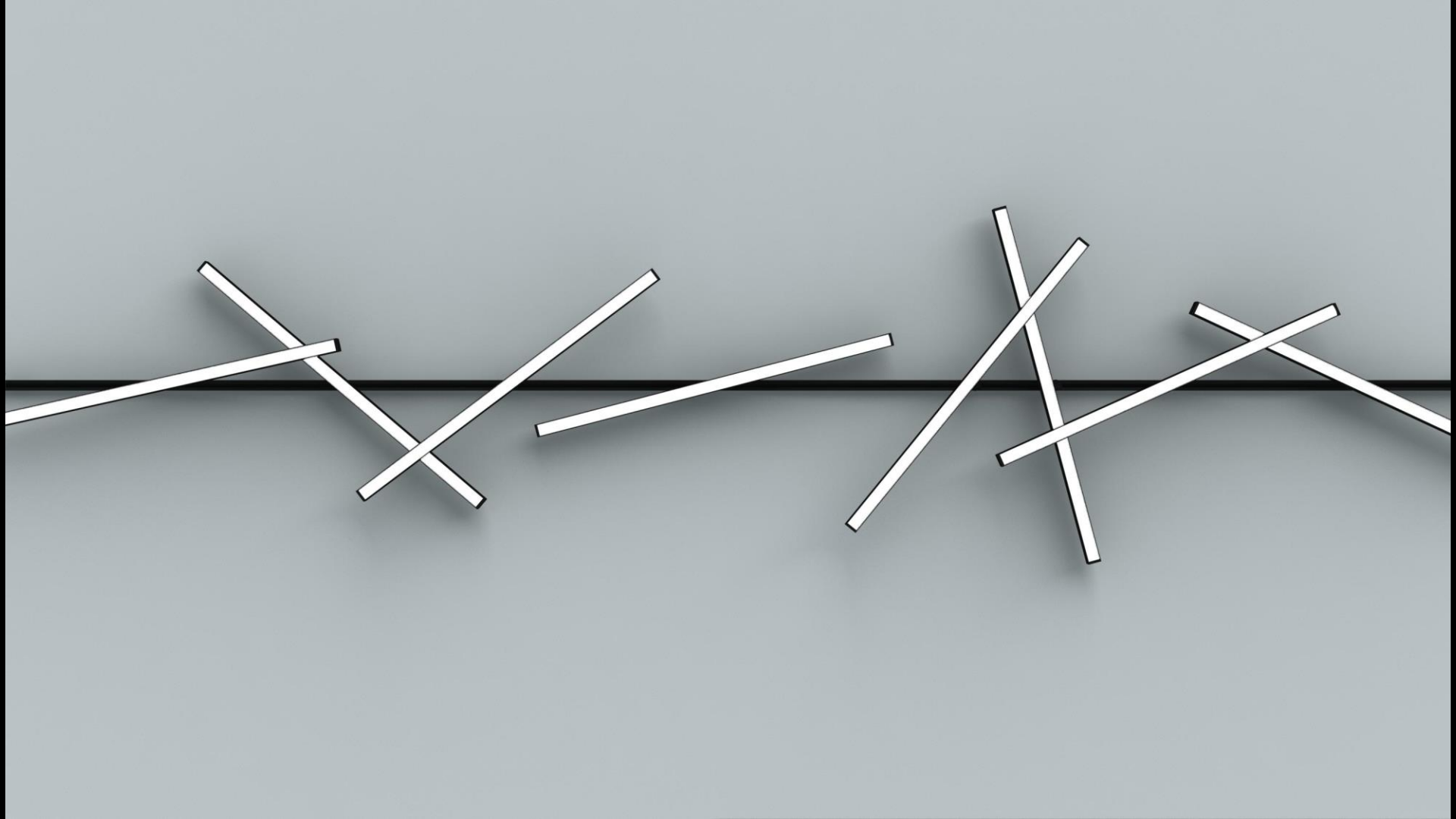



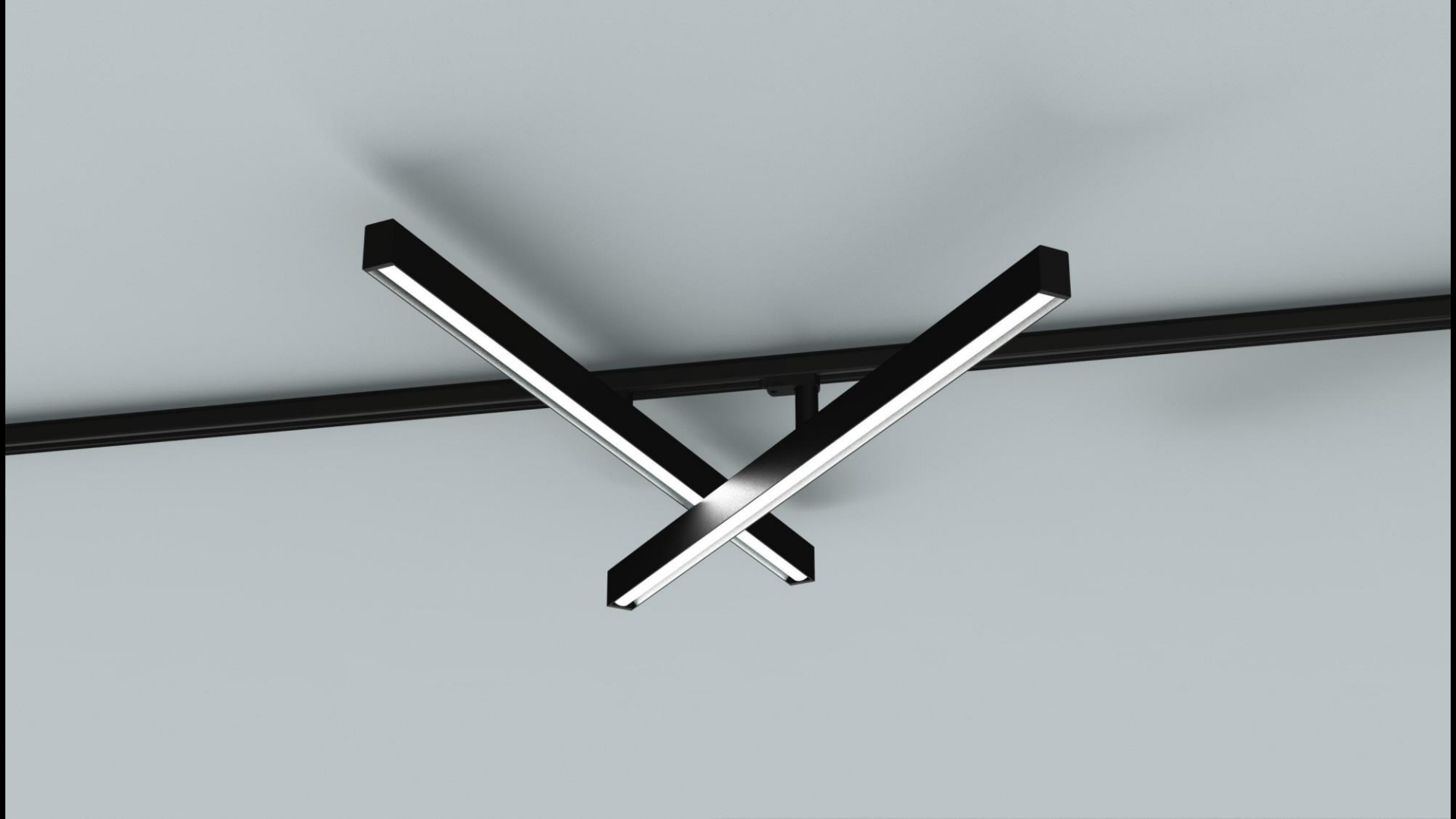





COPTER 3F

www.zumi.be/copter3F

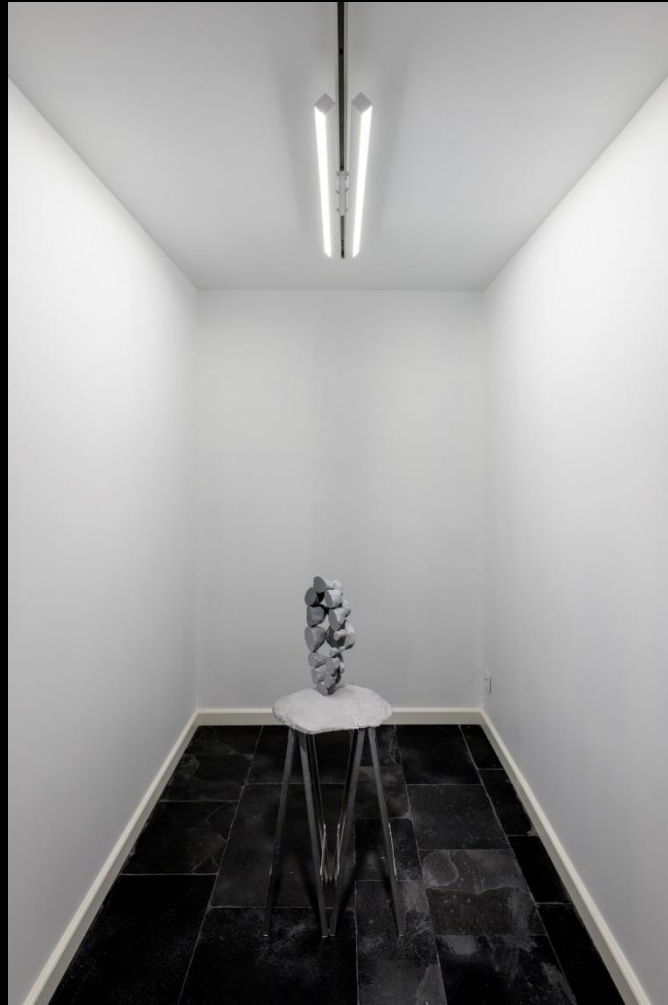
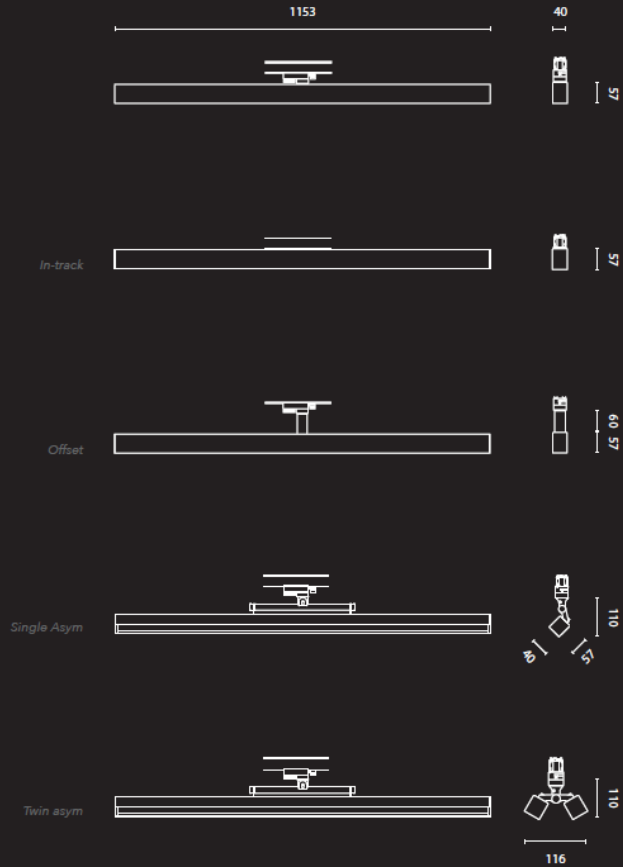



U40 TRACK



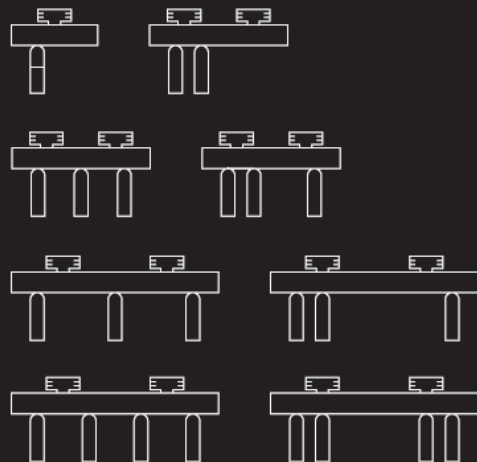
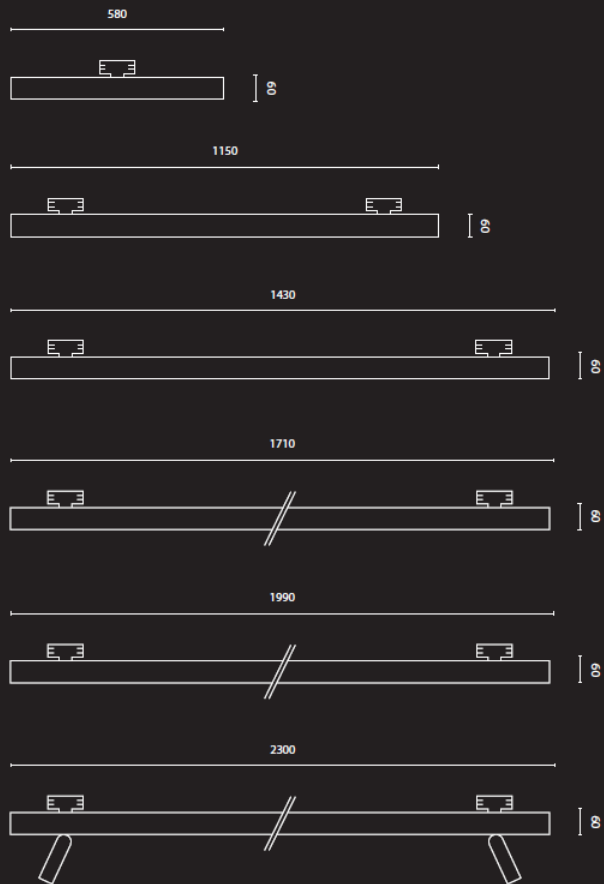

Eutrack

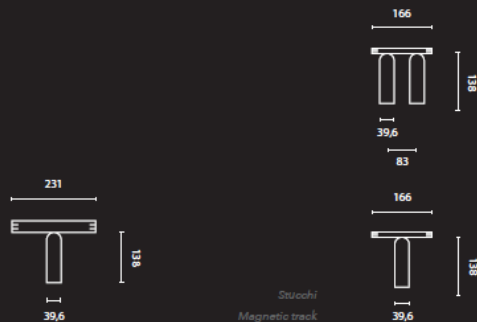

Stucchi
Onetrack

Stucchi
Magnetic track







U40 3F track PLK



U40 3F track
COPTER ASSYM

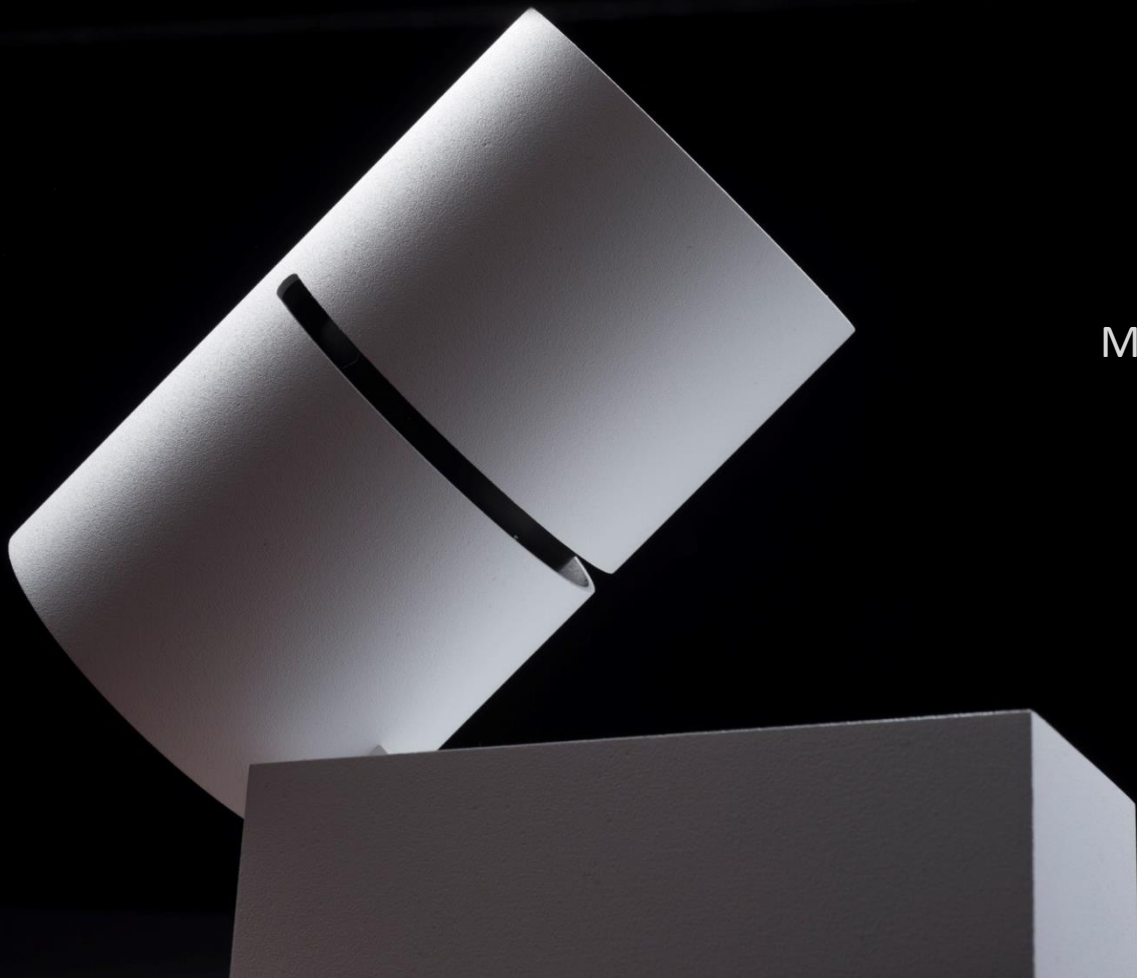

Mini SLINGSHOT



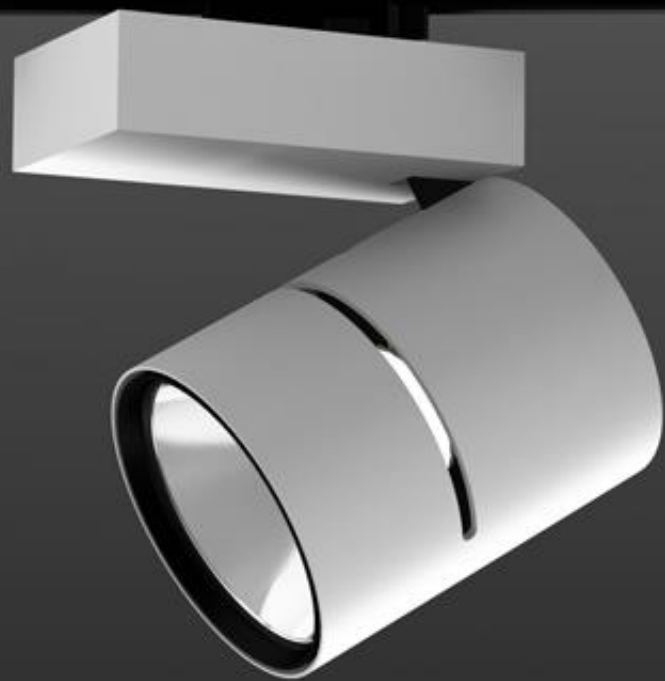

Slingshot

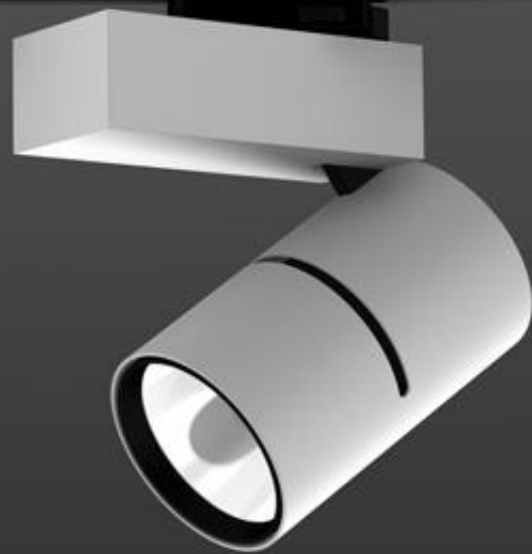

Mini Slingshot



LIGHT
+
SOUND



LIGHT & ACOUSTICS



GO DOWN

downlighters



LIGHT & ACOUSTICS

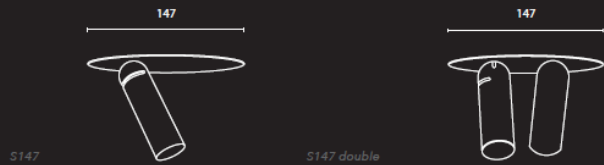
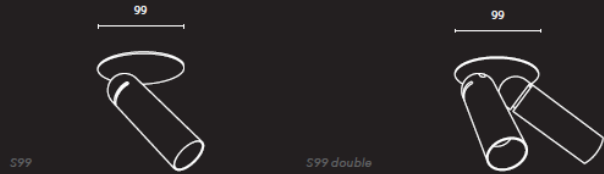
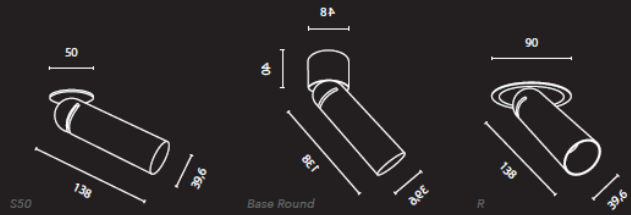

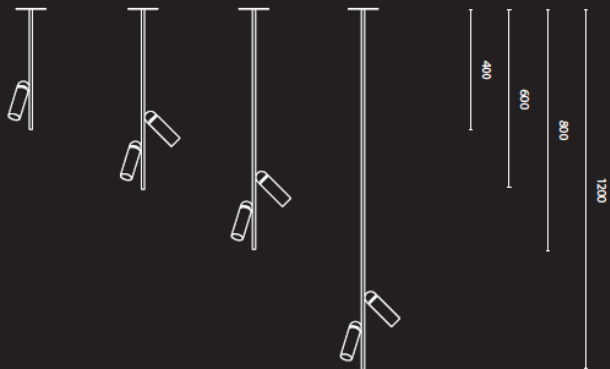
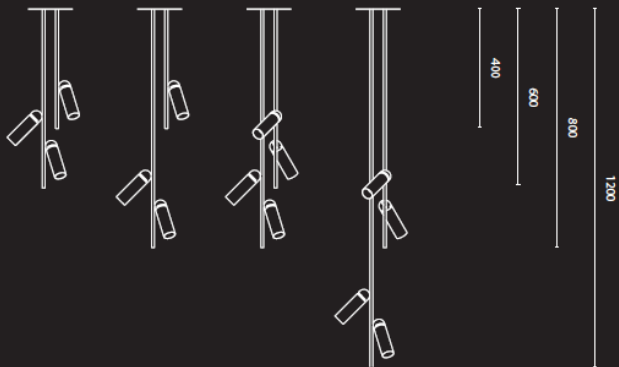

GO DOWN



PLK BASE

www.zumi.be/copter

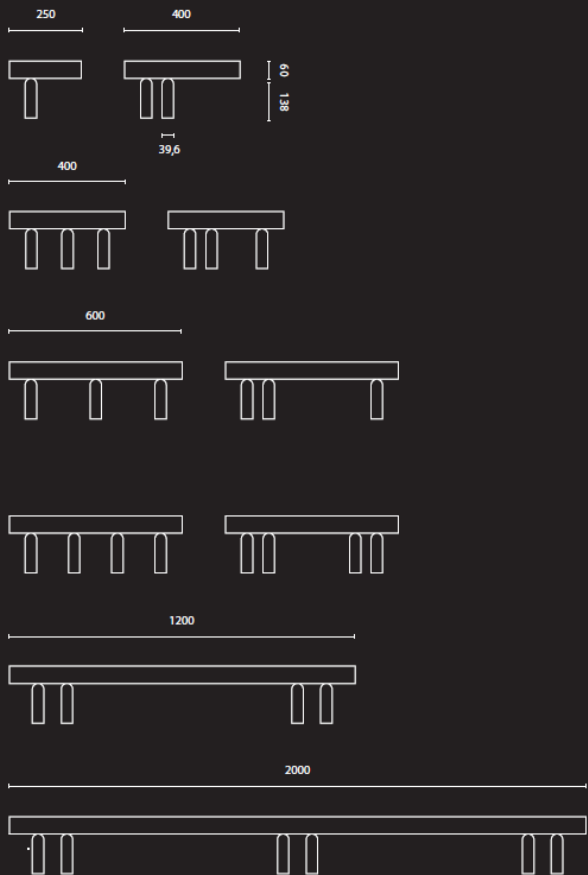

LIGHT & ACOUSTICS

CANNON

www.zumi.be/cannon

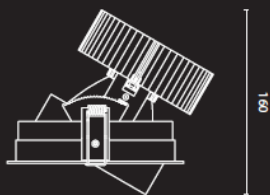

Ø 160

MINI CANNON

www.zumi.be/minicannon



Ø 116



up to 10 000 lumen



LIGHT & ACOUSTICS

UKKIE L

www.zumi.be/ukkieL



Ø 147

UKKIE M

www.zumi.be/ukkieM



Ø 99



LIGHT & ACOUSTICS



ON CEILING

Fixtures on ceiling



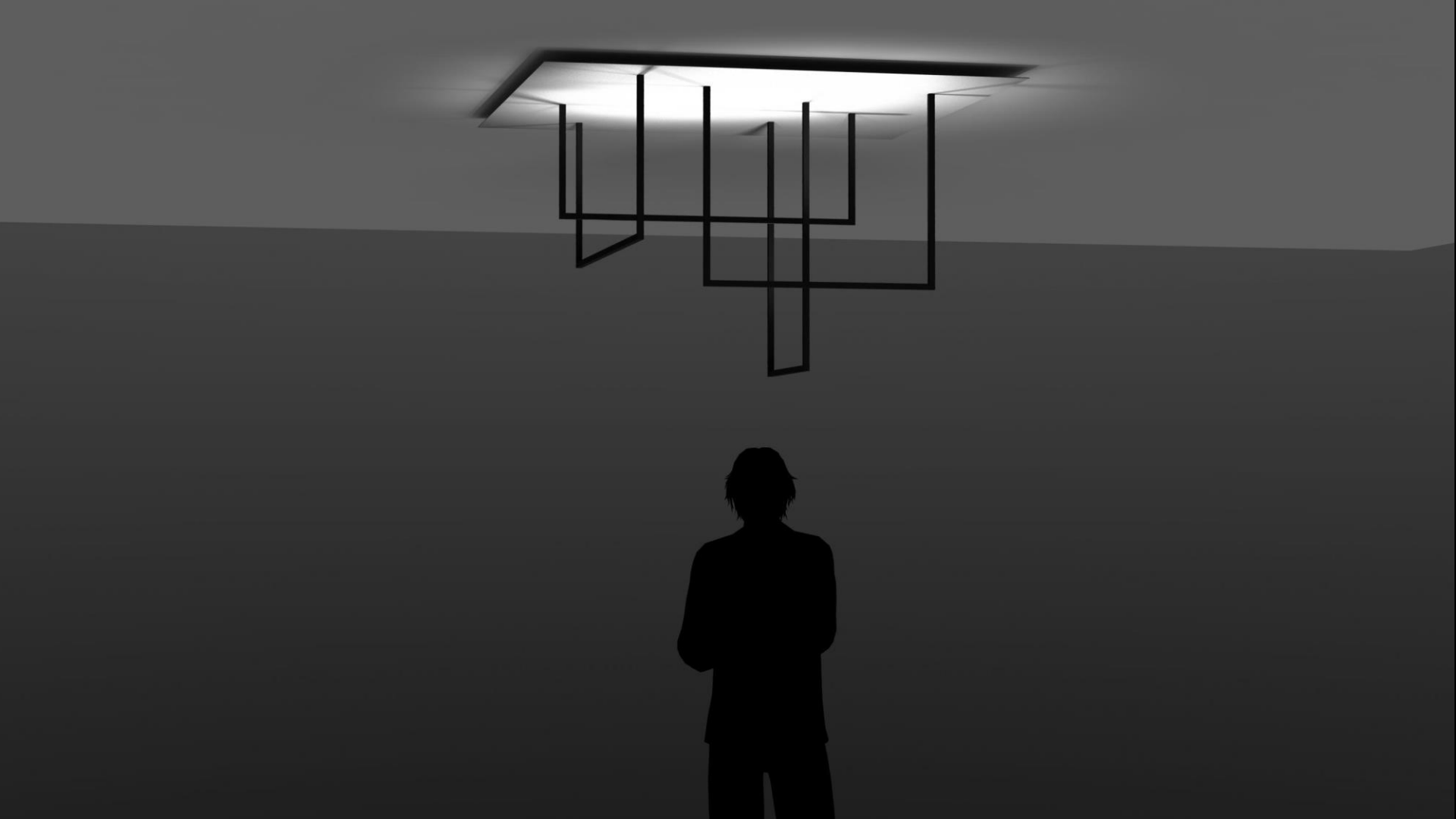

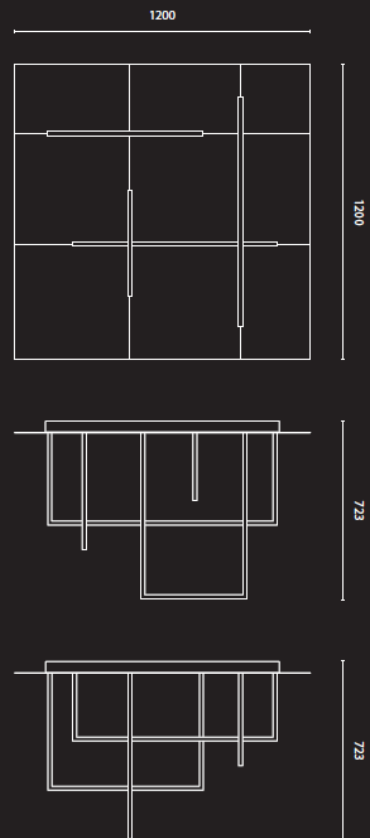
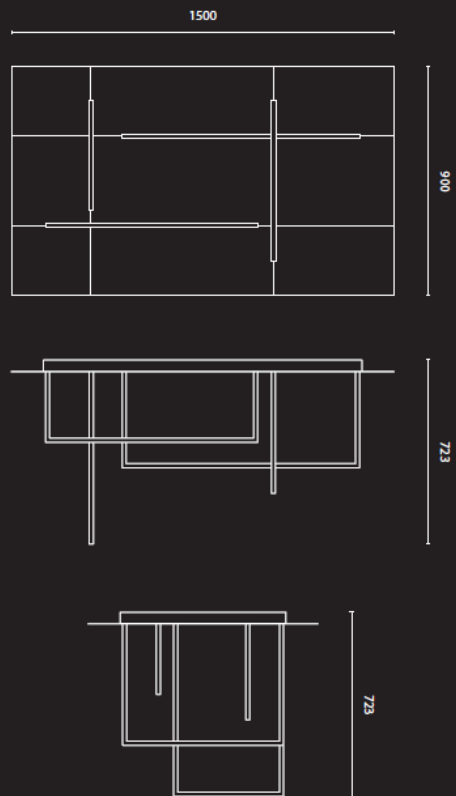



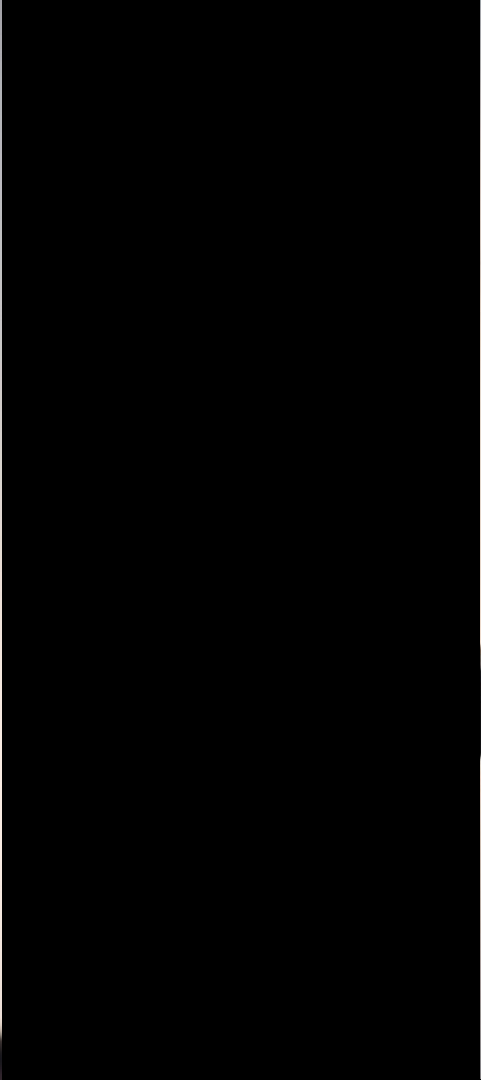
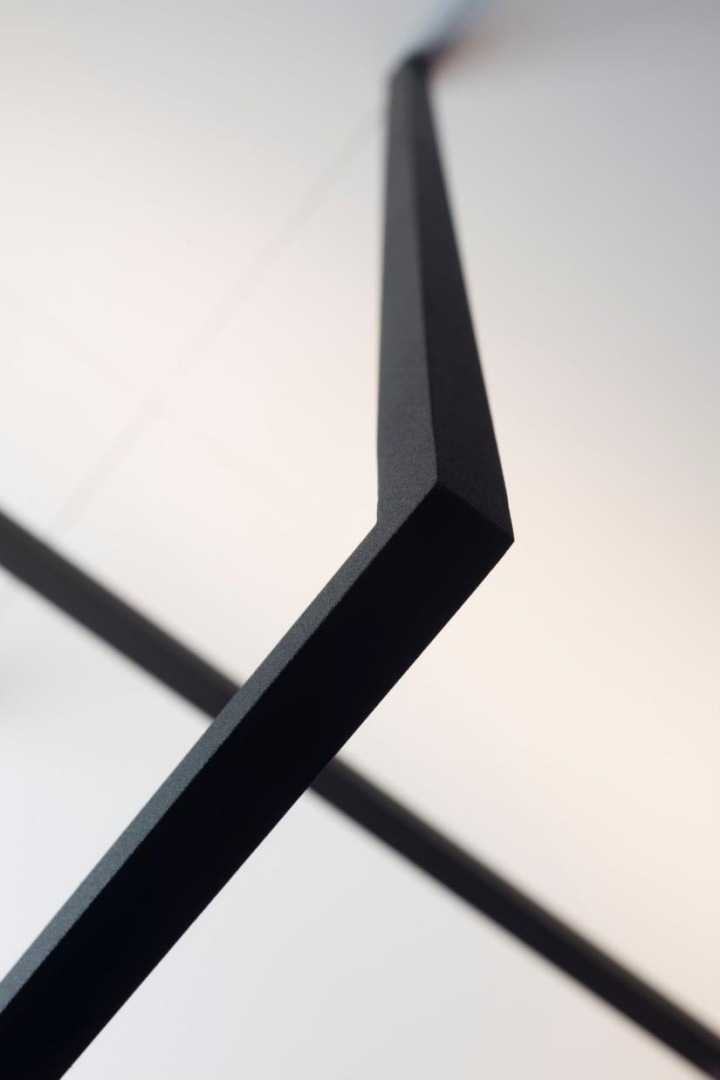

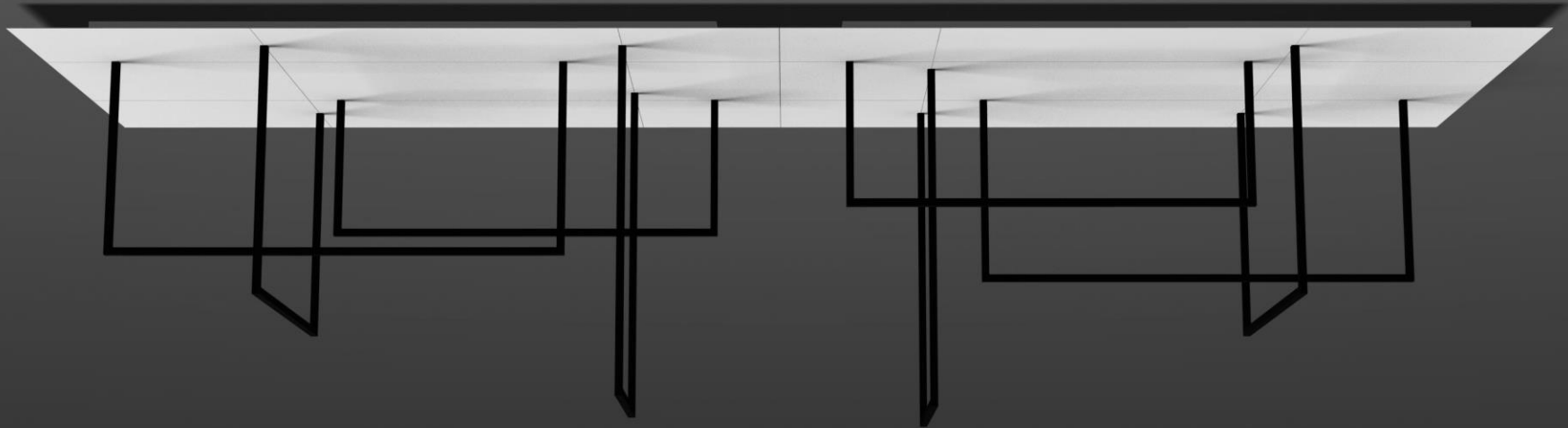

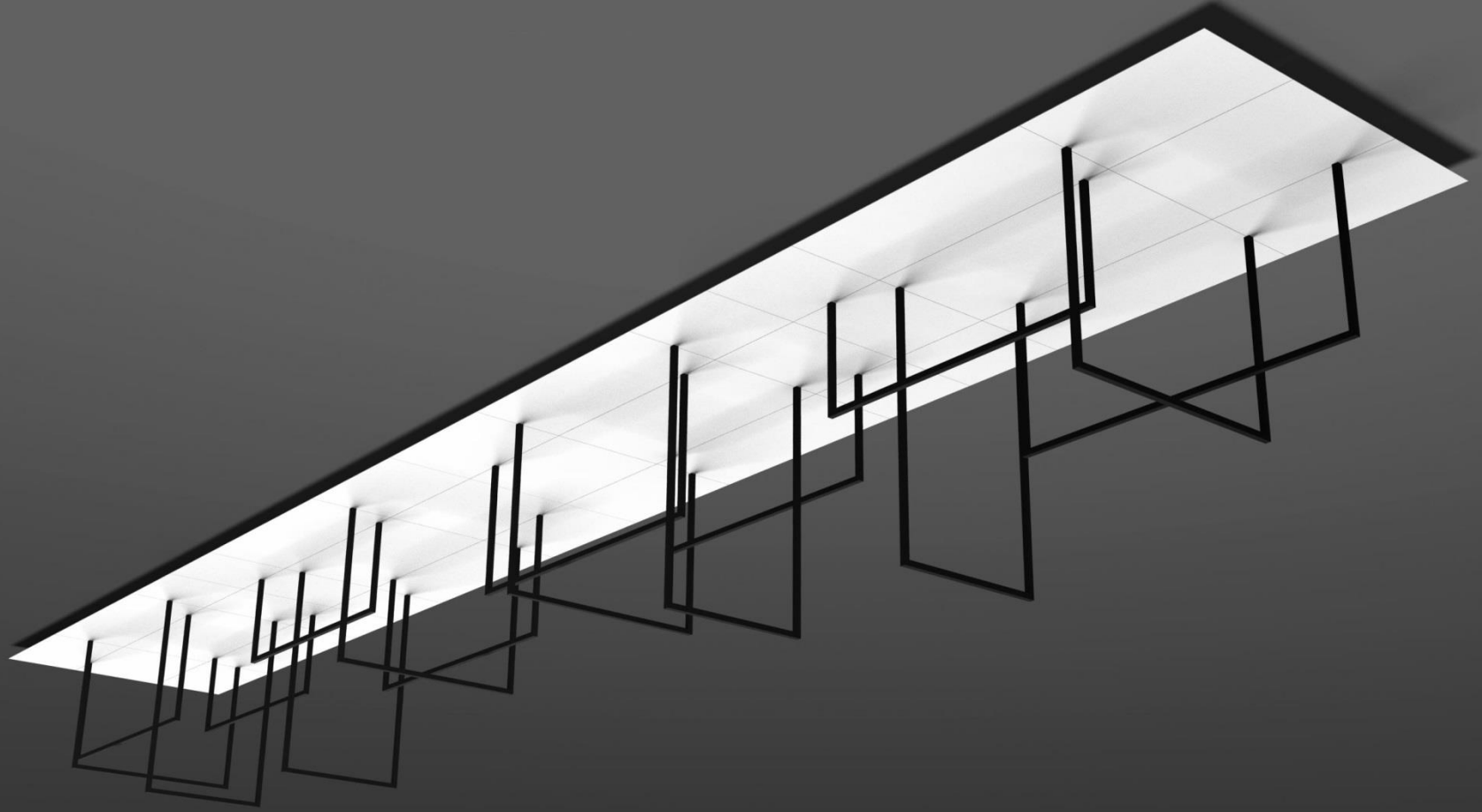



U-STONE

Carrières du Hainaut

Nero Marquina

Bianco Carrara

Emperador Marron







TUBULAR



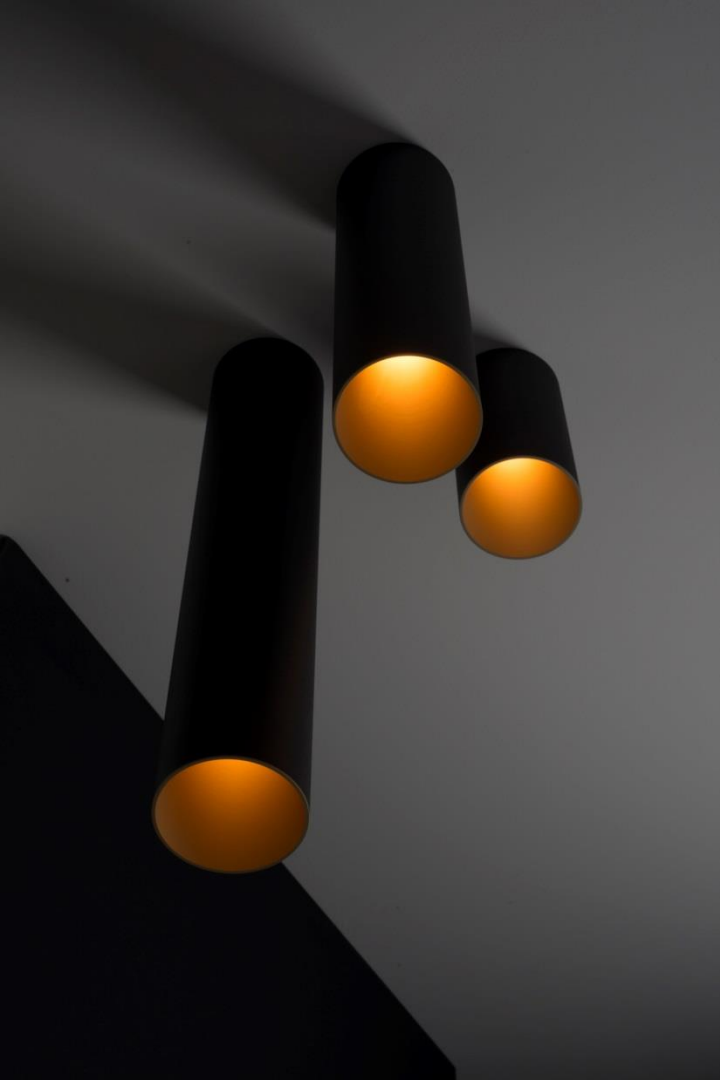

TUBULAR





ON WALL

Fixtures on wall



LIGHT & ACOUSTICS



ANGLE



ANGLE



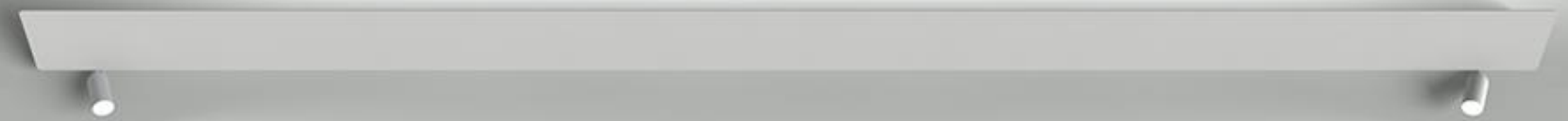

ANGLE



BEDLED



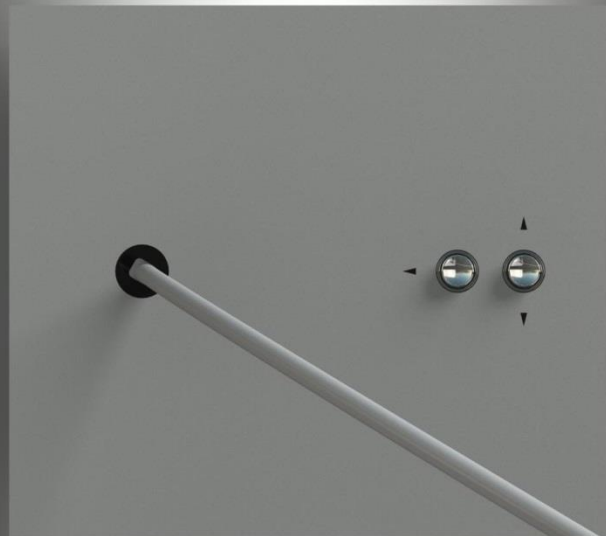

BEDLED

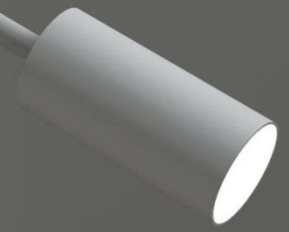



BEDLED



GO LINEAIR

profiles



LIGHT & ACOUSTICS



LIGHT & ACOUSTICS



ACOUSTIC SOLUTIONS

Acoustic panels



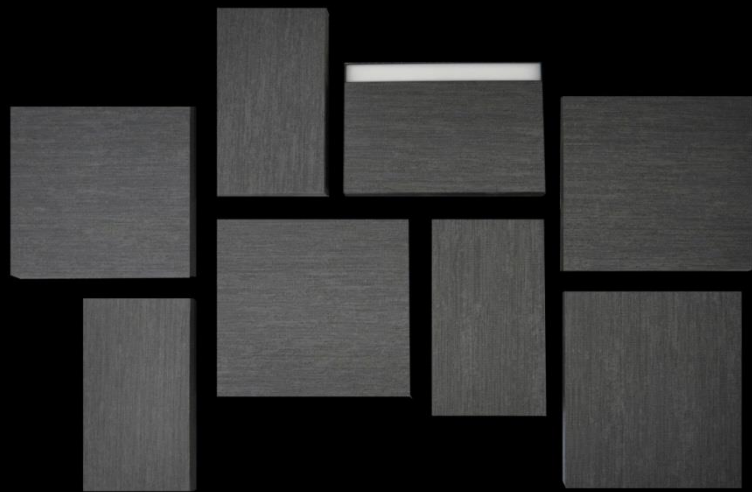

LIGHT & ACOUSTICS



BESPOKE

Measure made solutions



LIGHT & ACOUSTICS



LIGHT & ACOUSTICS



LIGHT & ACOUSTICS





Site Axel Vervoordt
Auto dialog





Site Axel Vervoordt
Auto dialog



LIGHT & ACOUSTICS



Site Axel Vervoordt
Auto dialog





Site Axel Vervoordt
Auto dialog



LIGHT & ACOUSTICS



Site Axel Vervoordt
Auto dialog



LIGHT & ACOUSTICS



BNP Parisbas Fortis
BXL



LIGHT & ACOUSTICS



BNP Parisbas Fortis
BXL





Carrières du Hainaut





CC De Benne
Blankenberge





STUDIO-D
Knokke



LIGHT & ACOUSTICS



Garage Vandenberghe
Sint Martens-Latem





Garage Vandenberghe
Sint Martens-Latem



Garage Vandenberghe
Sint Martens-Latem





Ghelamco Gent

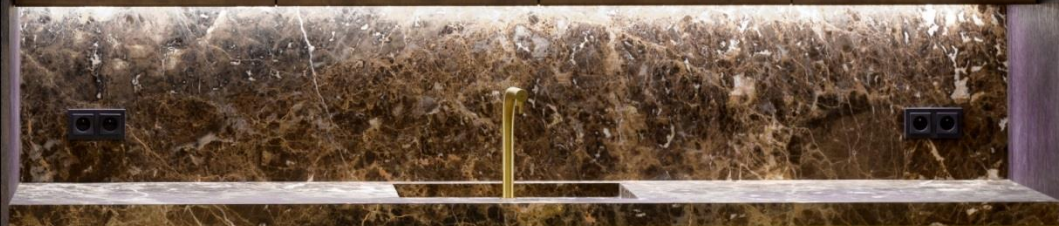

ICONIC CARS
Tienen



ICONIC CARS
Tienen





ICONIC CARS
Tienen



LIGHT & ACOUSTICS



LIGHT & ACOUSTICS



ART gallery
Black Swan
Bruges



LIGHT & ACOUSTICS



ART gallery
Black Swan
Bruges



LIGHT & ACOUSTICS



Tiles Tielt



LIGHT & ACOUSTICS



STUDIO-D
Knokke



LIGHT & ACOUSTICS



11

URBAN

CASUAL
FRESH
CREATIVE
INDIVIDUAL
NATURAL

STUDIO-D
Knokke



LIGHT & ACOUSTICS



STUDIO-D
Knokke





STUDIO-D
Knokke



LIGHT & ACOUSTICS



STUDIO-D
Knokke





Hotel
Koksijde



LIGHT & ACOUSTICS



Enjoy Concrete
Veurne



LIGHT & ACOUSTICS



LIGHT & ACOUSTICS



Ghelamco
Gent



LIGHT & ACOUSTICS

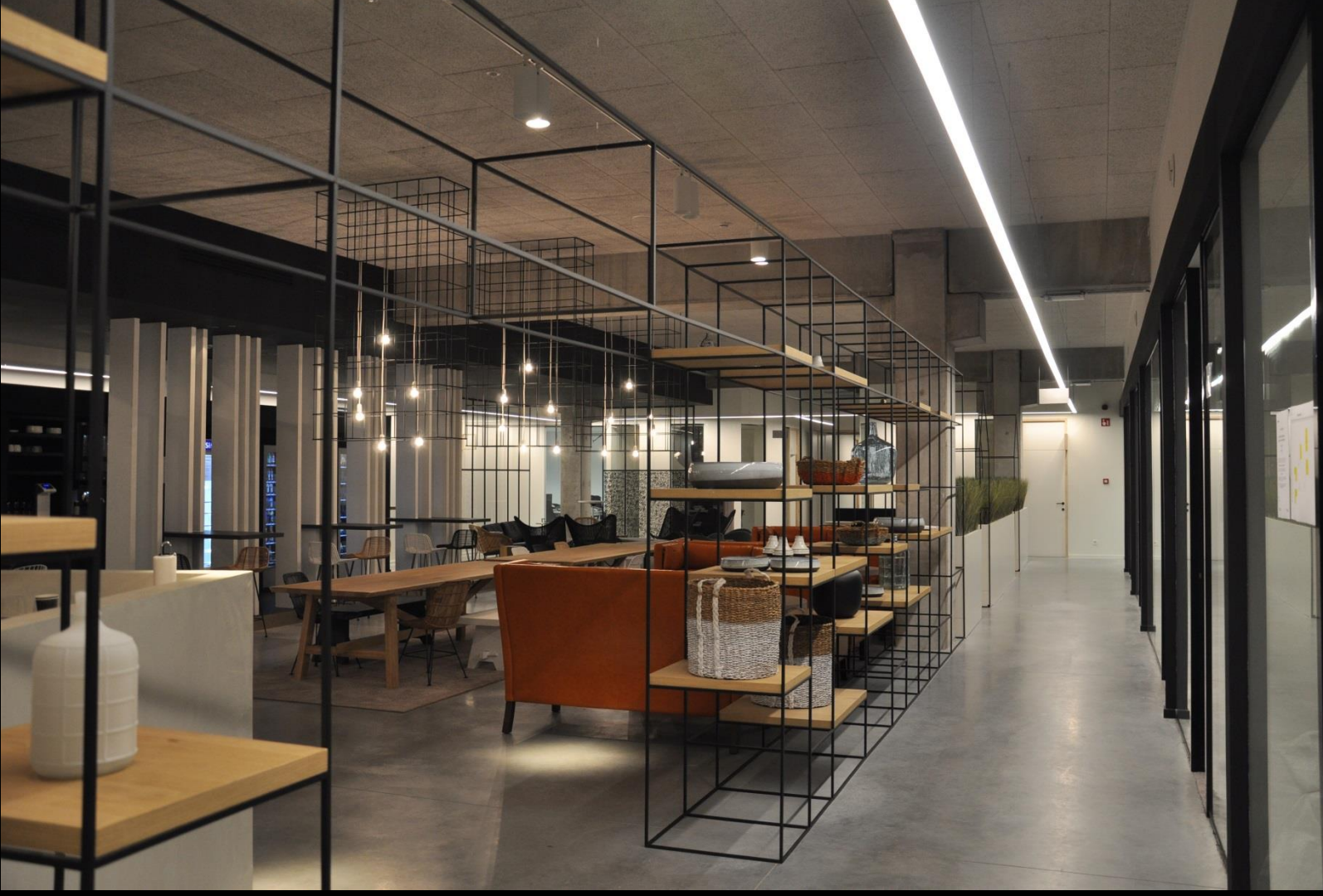

Ghelamco
Gent



LIGHT & ACOUSTICS



Ghelamco
Gent





Ghelamco
Gent





Ghelamco
Gent



LIGHT & ACOUSTICS



Immo
Knokke



LIGHT & ACOUSTICS



Office
Antwerp



LIGHT & ACOUSTICS



Office
Antwerp





Private LOFT
Aalst



LIGHT & ACOUSTICS



Private LOFT
Aalst





Private LOFT
Aalst



LIGHT & ACOUSTICS



Private LOFT
Aalst





Private LOFT
Aalst





Private LOFT
Aalst



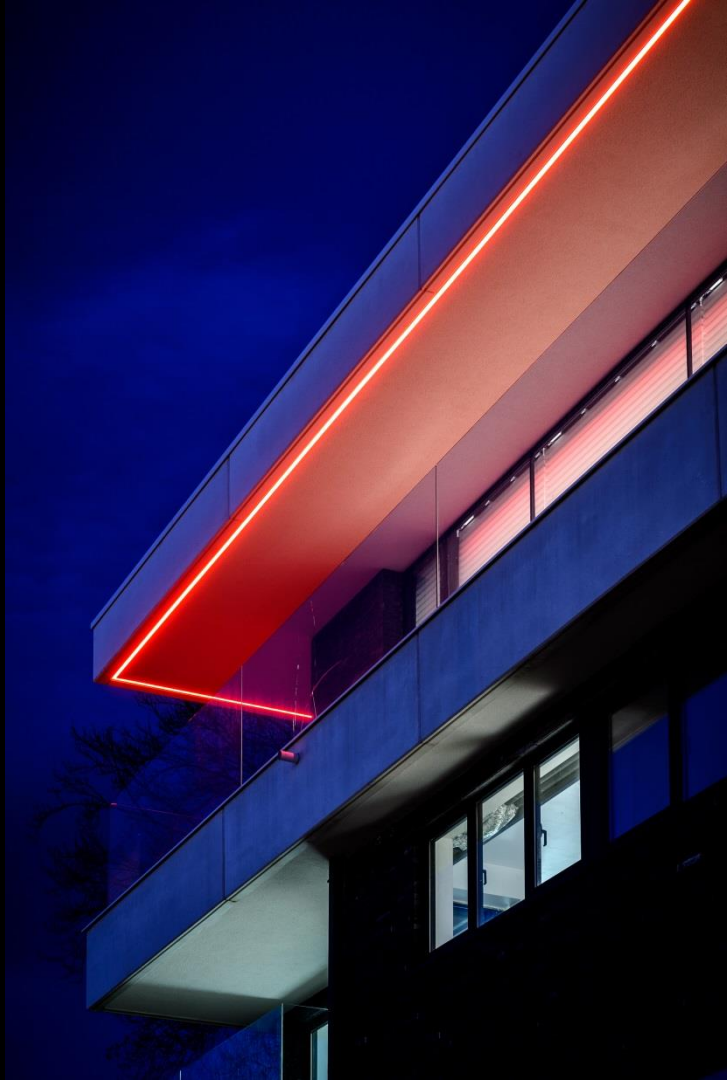

Private LOFT
Aalst





Shoes
Leuven





LIGHT & ACOUSTICS





LIGHT & ACOUSTICS





LIGHT & ACOUSTICS



LIGHT & ACOUSTICS

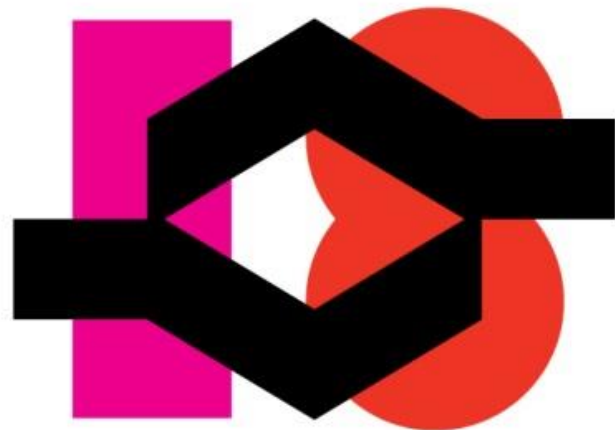

Overview *new items*
at Interieur Kortrijk 2018

Discover
us at

Biennale
INTERIEUR
2018
Kortrijk^{BE}
18.10–22.10



Leather

Stone by Carrières du hainaut

Marble

Felt

Copper en Gold by Abet Laminati

Graphic print

Forest color

ZERO waste



*High-tech LED
Acoustic solutions
Tunable White
DALI controlled*

— ACOUSTIC & LIGHT

"ACOUSTIC solutions are the INVISIBLE result for a better environment, LIGHT is the VISIBLE comfort for better health."

ACOUSTIC PANEL III is our standard collection in 2 different sizes: 600 x 600 and 600 x 400 with or without LIGHT. We bring new finishes from Abet Laminati, Wool and Felt. This collection can be applied as ceiling or wall solution. We also show ACOUSITC I which is a measure made solution with different possibilities of light integrations such as linear light, track light, downlight as well as other integrations such as smoke detectors, movement detectors, sound, Bluetooth application,...





LIGHT & ACOUSTICS





Why?

ACOUSTIC SOLUTIONS

Excessive noise levels in the living and working environment can lead to health problems. That is what the Netherlands National Institute for Public Health and the Environment (RIVM) says. The current noise levels in our living environment mainly cause annoyance and sleep disturbance. In addition, exposure to noise via physical stress reactions can lead to an increased risk of high blood pressure and cardiovascular disease and aggravate the symptoms in people who already suffer from cardiovascular disease. Exposure to noise can also lead to reduced performance.



Why?

ACOUSTIC SOLUTIONS

Sleep disturbance

Noise can affect sleep in different ways. Before and during sleep, it leads to an increase in sleep time, changes in sleep patterns, waking up in between and early awakening. But also the next day, after a disturbed sleep, effects are observed. These include bad mood, fatigue and reduced performance.

According to the World Health Organisation, long-term exposure to noise can lead to cardiovascular diseases.



Why?

ACOUSTIC SOLUTIONS

8

NIEUWS

HET BELANG VAN LIMBURG - WOENSDAG 15 JUNI 2011

Geluidsoverlast doodt jaarlijks 3.000 Europeanen

HASSELT - Elk jaar gaan in Europa meer dan anderhalf miljoen gezonde levensjaren verloren door gezondheidsproblemen ten gevolge van geluidsoverlast. Er sterven jaarlijks zelfs 3.000 Europeanen door aandoeningen die het gevolg zijn van geluidsstress. Dat staat in een rapport van de Onderzoeksraad van de Europese Unie. Het steeds toenemende wegverkeer is de belangrijkste bron van lawaaihinder.

Na luchtvervuiling is geluidsoverlast de omgevingsfactor met de grootste impact op de gezondheid. Langdurige blootstelling aan lawaai kan resulteren in onder meer slaapproblemen, vermoeidheid, depressie en stress, wat uiteindelijk kan leiden tot een verhoogde bloeddruk en hartfalen.

Uit een studie van de Wereldgezondheidsorganisatie (WHO) en de Europese Gezondheidsraad blijkt nu dat het lawaai in Europa anderhalf miljoen gezonde levensjaren kost. Ongeveer 61.000 jaren gaan verloren door hartziekten, 903.000 levensjaren door slaapproblemen, 22.000 jaren door tinnitus (oorsuizen) en 587.000 door de frustraties als gevolg van de overlast. "Het wegverkeer alleen al is jaarlijks ver-

antwoordelijk voor het verlies van een miljoen gezonde levensjaren", stelt de studie.

Ziekmaker

Het Kenniscentrum Geluidsisolatie (KGI) in Nederland stelt dat 700.000 Nederlanders zich bijna dagelijks ergeren aan straatlawaai. "Mensen worden daar echt ziek van, zelfs al denken ze niets te horen. Uit een studie is bijvoorbeeld gebleken dat mensen die onderaanlegroutes bij grote luchthavens wonen en beweren dat ze daar geen hinder van ondervinden, toch een hogere hartslag hebben bij elk vliegtuig dat overkomt. Ook als ze slapen", stelt Lucas Keizer van het KGI, die er nog aan toevoegt dat ook "interne geluidshinder

- zoals het schuiven van stoelen, voetstappen, of het gezoom van ventilatiesystemen - niet zelden een ziekmaker is.

Volgens de Nederlandse onderzoekers overlijden jaarlijks 3.000 Europeanen en 700 Nederlanders door aandoeningen die het gevolg zijn van geluidsoverlast. Dat zijn er meer dan door ongevallen in het verkeer.

Verkeer

Voor Vlaanderen bestaan zulke cijfers niet. "Maar het Mira-rapport van de Vlaamse overheid schat dat elk jaar in Vlaanderen 6.528 gezonde levensjaren verloren gaan wegens slaapproblemen en hartziekten als gevolg van lawaai", stelt Dik Botteidooren, audioloog van UGent. "We zouden de geluidshinder sterk kunnen doen dalen door de snelheid in het verkeer te matigen", denkt hij. Andere pogingen om de geluidsoverlast te doen dalen met geluidschermen, fluisterasfalt, stille motoren en bunden, zijn door de toegenomen verkeersdrukte overigens tenietgedaan.

GW



Volgens onderzoek van de Wereldgezondheidsorganisatie en de Europese Gezondheidsraad kost geluidshinder in Europa elk jaar anderhalf miljoen gezonde levensjaren.

Foto HB.nl

ZUMI

Why?

ACOUSTIC SOLUTIONS AND **LIGHT**
HUMAN CENTRIC LIGHTING
MAKES THE DAY LIGHT.







Our daily world

ACOUSTIC SOLUTIONS AND **LIGHT**
HUMAN CENTRIC LIGHTING
MAKES THE DAY LIGHT.



Artificial light is fixed from wake-up to go-to-sleep

-  On a sunny day people outside get **100 000 lux**
-  On a cloudy day **10 000 lux**
-  Indoor in offices people get **500 lux**
-  And in school only **300 lux**



People spend
90%
Of their time indoor

ACOUSTIC SOLUTIONS AND LIGHT

HUMAN CENTRIC LIGHTING

MAKES THE DAY LIGHT.



The problem

Today there is a **disconnect** between natural and artificial light with regard to intensity, color and dynamics of light



.....too little light in daytime



.....too much light by night

Consequences

- Poor circadian entrainment, problems with body clock similar to jet-lag.
- Problems with sleep & alertness.
- Disturbance of the hormone system.
- Compromised mood, functioning, well-being and health....



The impact of light

Light has an effect on



Vision

Sight



Body

*Alertness,
Cognitive
Performance
and sleep/wake
cycle*



Emotion

*Mood, energize
and relaxation*

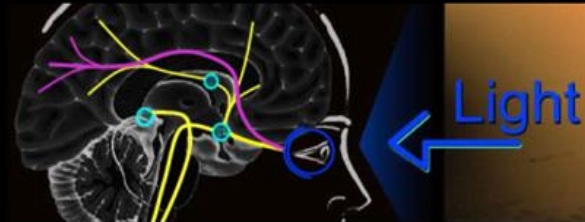

ACOUSTIC SOLUTIONS AND **LIGHT**
HUMAN CENTRIC LIGHTING
MAKES THE DAY LIGHT.



THE CIRCADIAN RHYTHM.

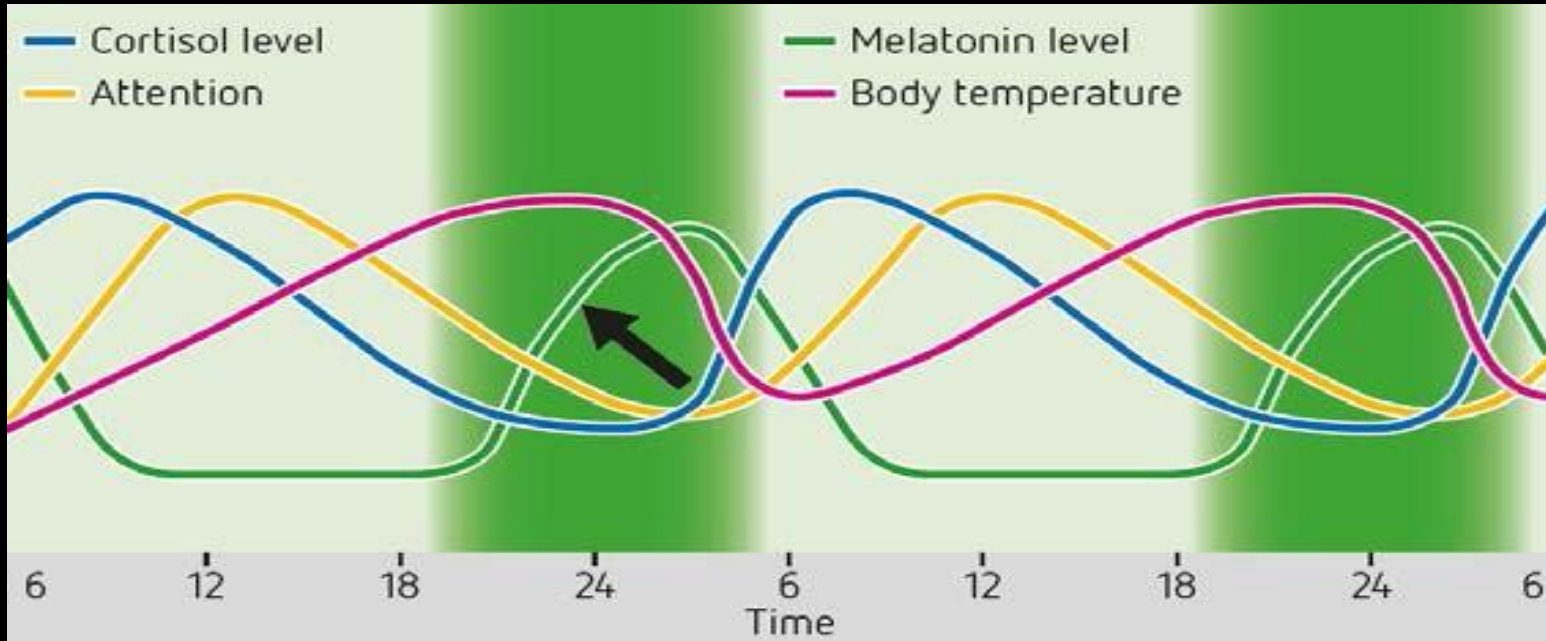

— U-STONE BY CARRIÈRES DU HAINAUT

*"I am unique. I am authentic. Touch me. Touch me.
I am the Blue Stone of Hainaut."*

U-stone is a minimalistic fixture with high quality LED in different light colors, dimmable or not dimmable. The fixture is made out of a type of stone with a lifetime of more than 345 million years of history.



— U-LEATHER

"Style is a way to say who you are without having to speak."

U-leather is a minimalistic fixture with high quality LED in different light colors, dimmable or not dimmable. The fixture is finished with timeless high quality leather.

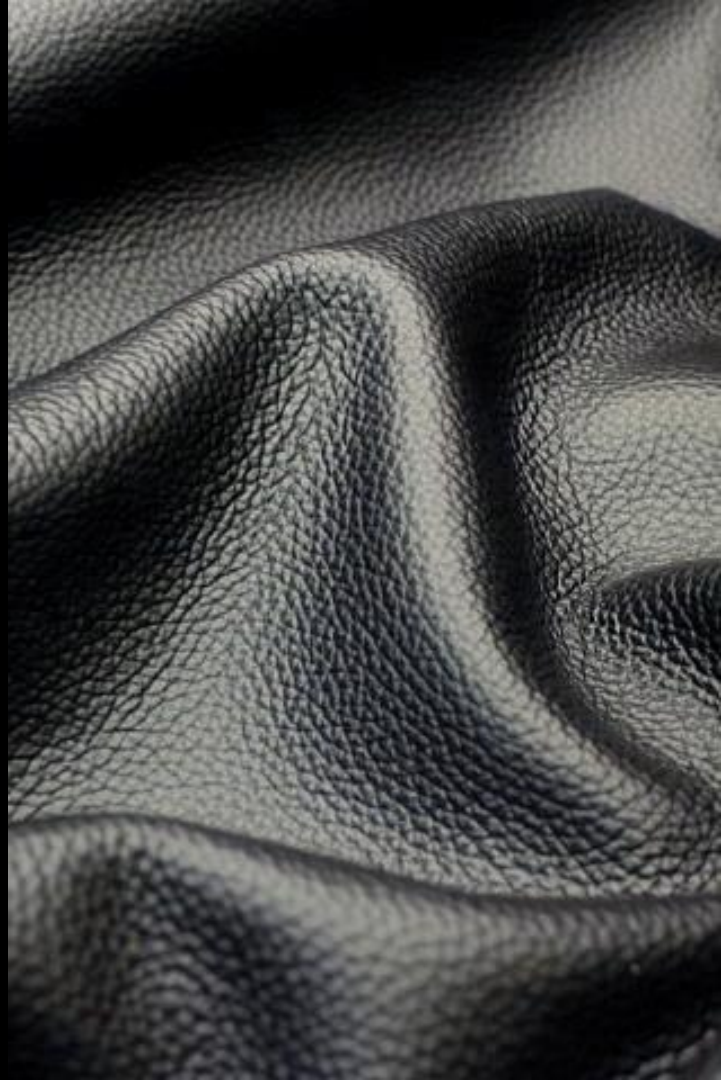

— ZERO WASTE AND CURVY

“Recycle the past, redesign the present, shape the future.”

“Design based on ‘leftovers’ from the quarry” is the starting point for the models ZWT and ZWD. “Zero Waste Table” and “Zero Waste Desk” are two contemporary lamp designs made from one or two types of natural stone.

“CURVY” is a modular lighting system that allows you to create your own ceiling or wall lamp by combining different curves and end pieces. Introduction of graffiti design, “Curvy” is trendsetting and innovative and enables us to create bespoke lamps for each exclusive project.





ON OUR WAY TO
zero
WASTE

Designers: Danny Hoorelbeke en Wim Demoen





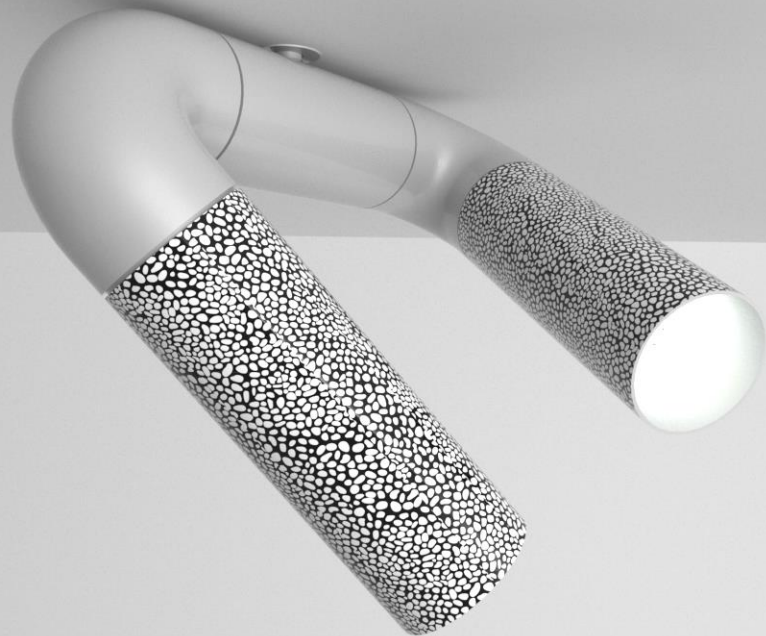



— PLK SPOT

"Simplicity is the ultimate sophistication."

The PLK spot has a simple design that fits into any architecture. There are many application possibilities: recessed, surface mounted, profile mounted, stand-alone... Finish available in black, white, champagne, bronze and forest.



introducing graphics on lighting fixtures

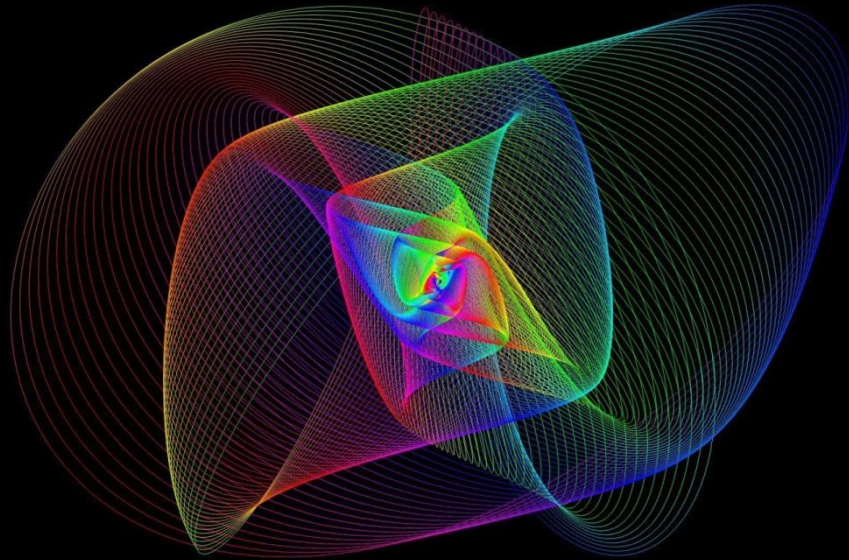



© Rafael Pauwels





LIGHT & ACOUSTICS

HALL 4 LO8
LANDMARK ZONE

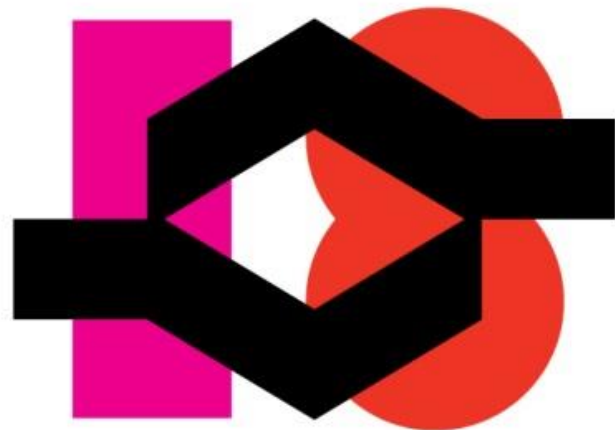

Discover
us at

Biennale
INTERIEUR
2018
Kortrijk^{BE}
18.10–22.10

andlhuber

ZUMI
LIFE & BUSINESS
THE WAY OF
@ f v m

ZUMI



ZUMI









Participant
in the
INTERIEUR
2018
VIP Tours
for (Interior)
Architects

Supported by
POM

Organized by
www.dorlandspines.com





LIGHT & ACOUSTICS